

Rubber Selection Chart



Physical Properties

Durometer hardness Range (Shore A) _____
 Tensile Strength (m Pa) _____
 Maximum Elongation (%) _____
 Compression Set _____
 Resilience _____
 Gas Impermeability _____
 Electrical Resistivity (polymer) _____
 High Temperature Service (max oC) _____
 Low Temperature Service (min oC) _____

Mechanical Properties

Impact Strength _____
 Abrasion Resistance _____
 Tear Resistance _____
 Cut Growth _____
 Bonding to Rigid Materials _____

Resistance Ratings

Weather - Sunlight Ageing _____
 Oxidation _____
 Ozone Cracking _____
 Radiation _____
 Water _____
 Alkali Dilute / Concentrated _____

 Acid Dilute / Concentrated _____
 Aliphatic Hydrocarbons (petrol, kerosene) _____
 Aromatic Hydrocarbons (benzene, toluene) _____
 Halogenated Hydrocarbons (degreaser, solvents) _____
 Alcohol _____

	HYPALON® (Chlorosulphonated polyethylene)	Silicone (Polysiloxane)	Viton® (Fluoroelastomer)	Butyl (Isobutyleneisoprene)	EPDM (Ethylene-Propylene)	Nitrile (Acrylonitrile-Butadiene)	Neoprene (polychloroprene)	SBR (Styrene Butadiene)	Natural Rubber (Natural Polyisoprene)
	50-90	40-80	65-90	40-80	40-90	40-100	30-90	40-90	25-100
	20	10	20	20	20	28	28	24	30
	500	700-	300	650-G-	600	550	600	600	650
	G-F	G	E-G	F	E-G	G	G	G	E
	F	P	F	F	G	G	E	G	E
	E	F	E	E	G	G	G	F	G
	E	E	G	E	E	F-P	F	E	E
	125	300	325	125	150	125	125	110	105
	-40	-105	-45	-45	-55	-50	-40	-50	-50
	G	F	G	G	G	F	G	E	E
	E	F	G	F	G	E	E	E	E
	G	F	G	G	F	G	G	G	E
	E	G	G	E	F	E-G	E-G	E	E
	E	E	E	E	E	P	G	F-P	F-P
	E	E	E	E	E	G	E	F	G
	E	E	E	E	E	F	E	N	N
	G	G	G	G	G	G	G	G	G
	G	E	E	E	E	E	E	E-G	E/G
	E/E	E/E	E/E	E/E	E/E	G/G	E/E	G/G	E/G
	E/E	G/F	G/F	E/E	E/E	G/G	E/E	G/G	E/G
	F	F	E	N	N	E	F	N	N
	G	N	E	N	N	E-G	G	N	N
	P	N	E	N	N	G-F	P	N	N
	E	N	E	N	N	G-F	E	G	E-G
	G	G	E	E-G	G	G	G	G-F	F-G

WHEEL ARCH FLARES

RE FENDER 1.

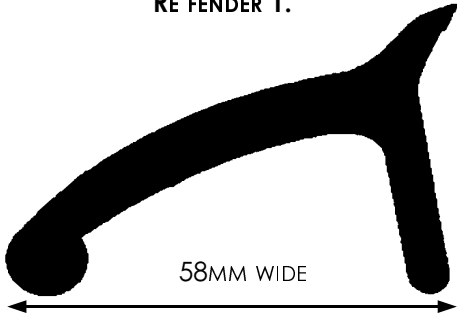

58MM WIDE

RE FENDER 2.

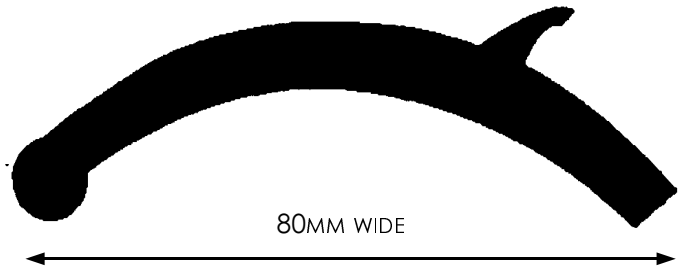

80MM WIDE

WHEEL ARCH FLARES BOTH COME IN 30 METRE COILS

TANK STRAPS

25MM



RETS25

40MM

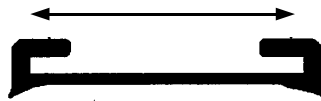

RETS40

50MM



RETS50

70MM



RETS70

Curtain Rubber

A
11.

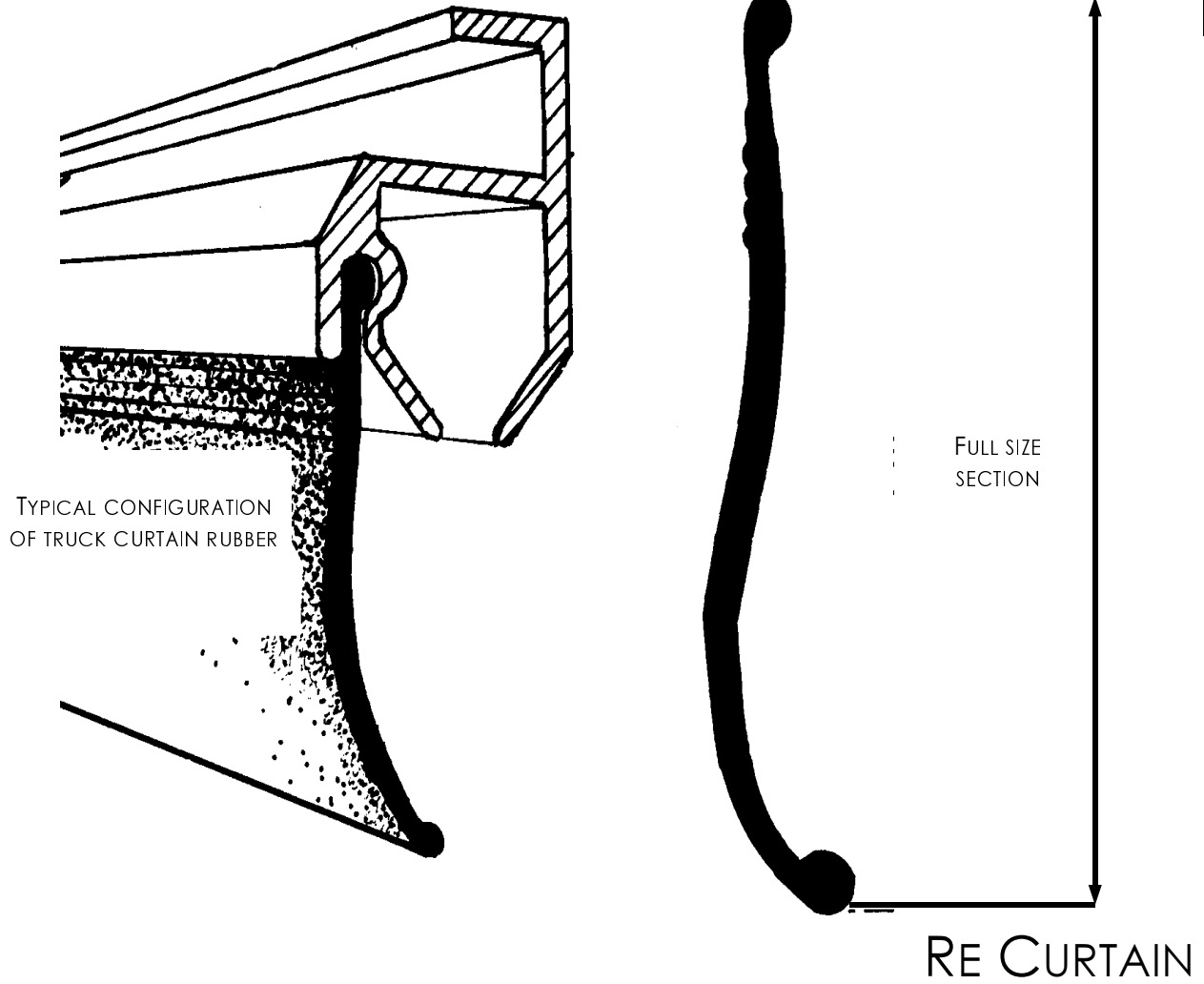

RUBBER STAIR-NOSE

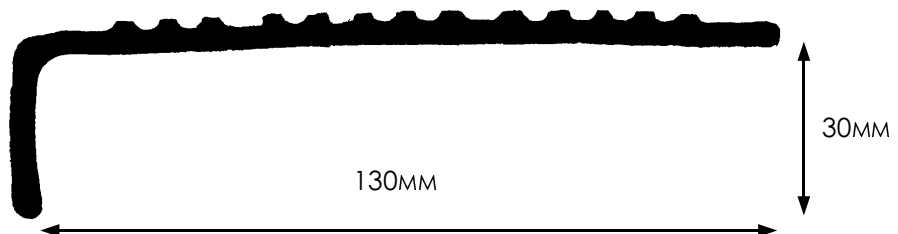

RE 1475

Extruded Rubber

Wheel Chocks

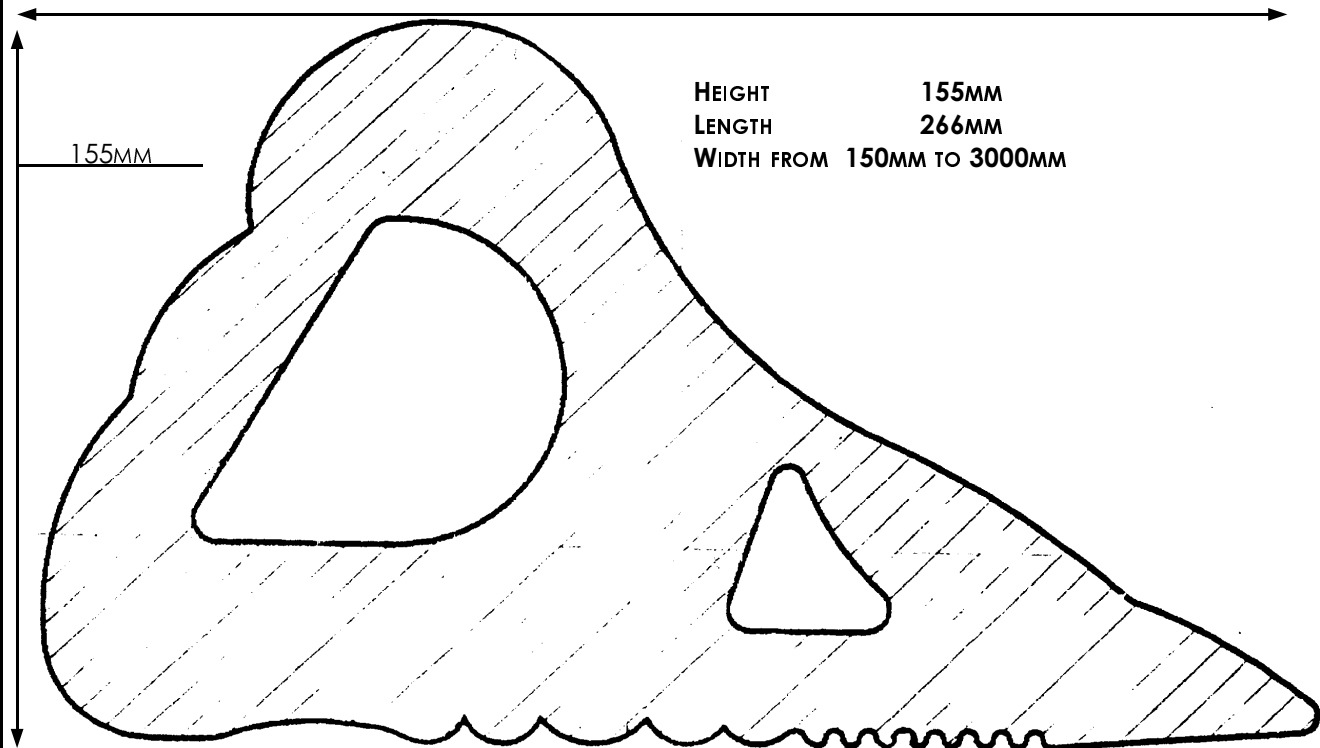

Heavy duty buffer

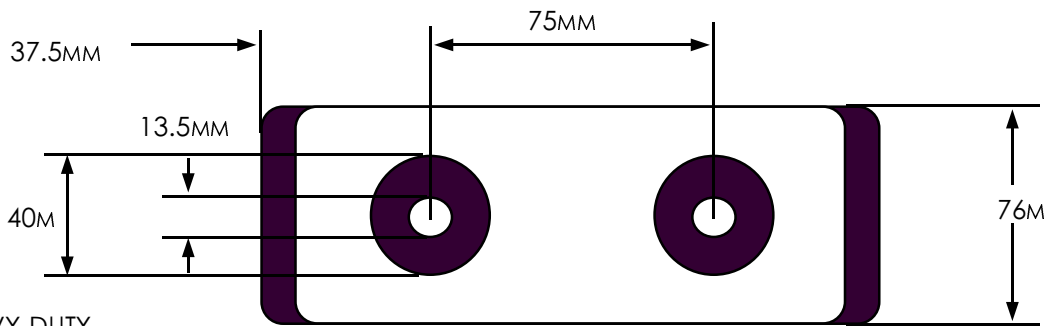

THIS HEAVY DUTY MOULDED BUFFER IS SUITABLE FOR ATTACHMENT TO TRUCK AND HEAVY VEHICLE BUMPER BARS AND FOR INDUSTRIAL APPLICATIONS WHERE HEAVY DUTY NON CYCLIC BUFFING IS REQUIRED eg FIRE DOORS.

HARDNESS - 75 DURO

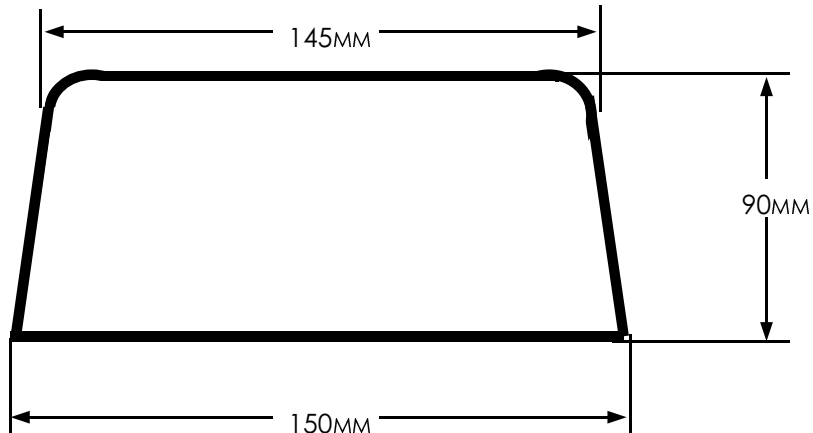

TRUCK SLEEPER CAB JOINING SEAL

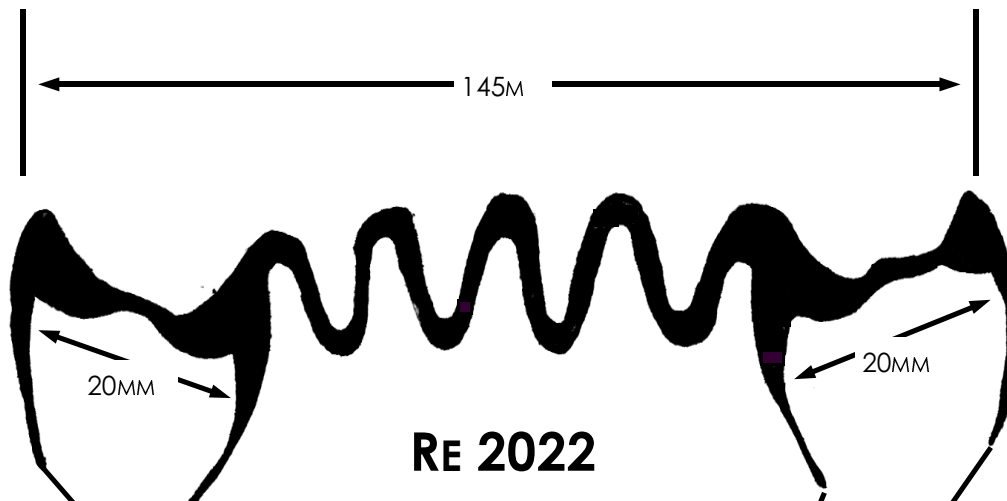

Extruded Rubber

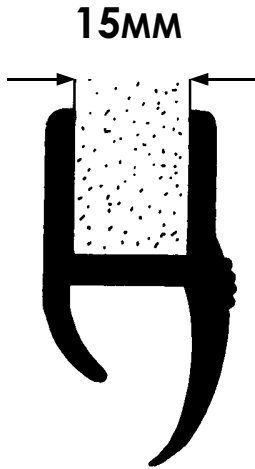

RES 15H
DOUBLE LIP

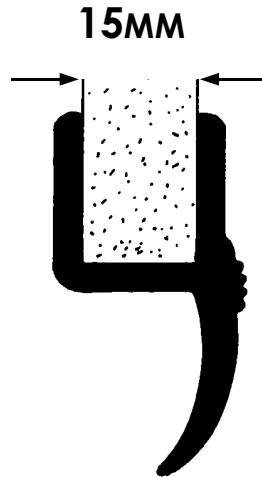

RES 15SL
SINGLE LIP

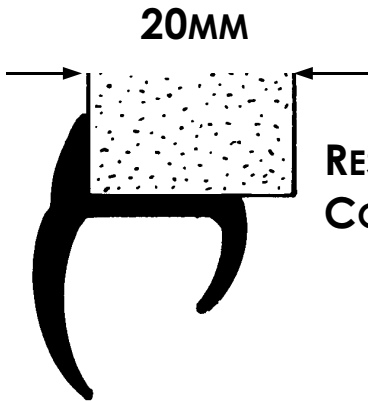

RES 20JC
CONTAINER TYPE

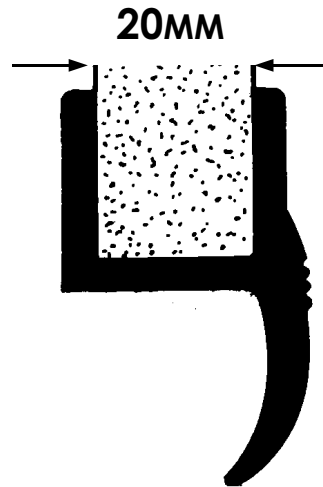

RES 20SL
SINGLE LIP

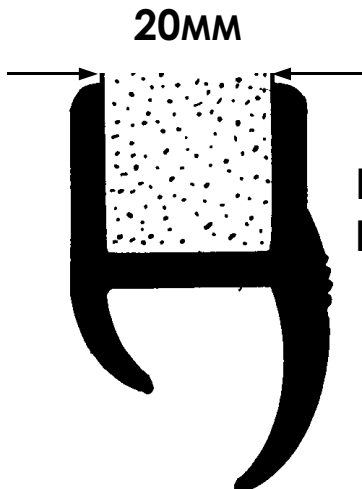

RES 20H
DOUBLE LIP

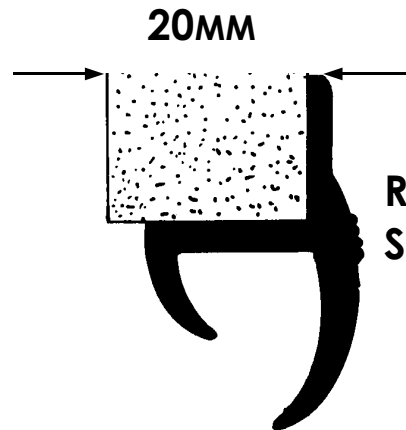

RES 20J
SINGLE LEG

Extruded Rubber

A
15.

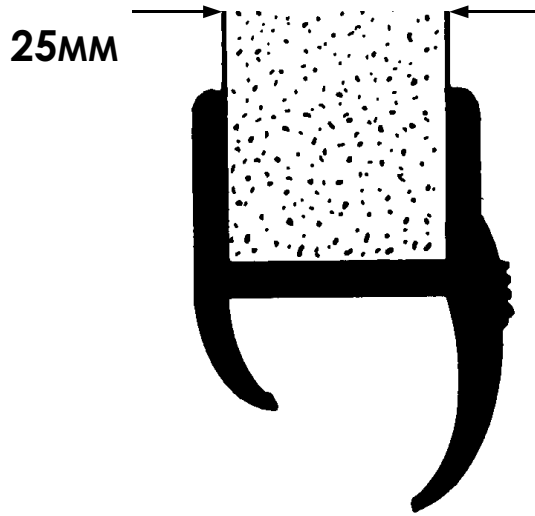

RES 25H
DOUBLE LIP

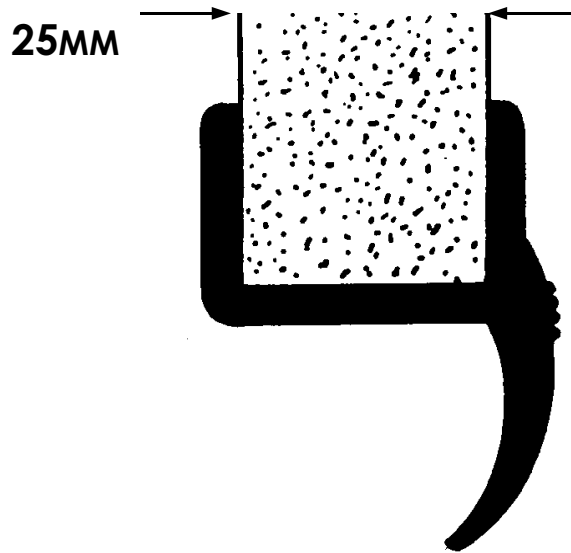

RES 25SL
SINGLE LIP

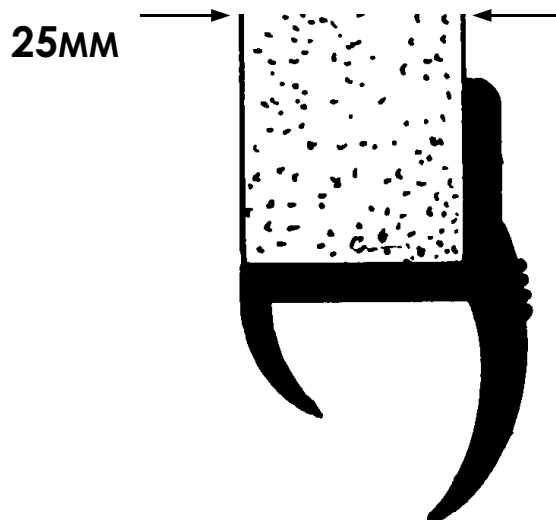

RES 25J
SINGLE LEG

ALL SUPPLIED IN 30 METRE COILS

A
16.

Extruded Rubber

RES 32H
DOUBLE LIP

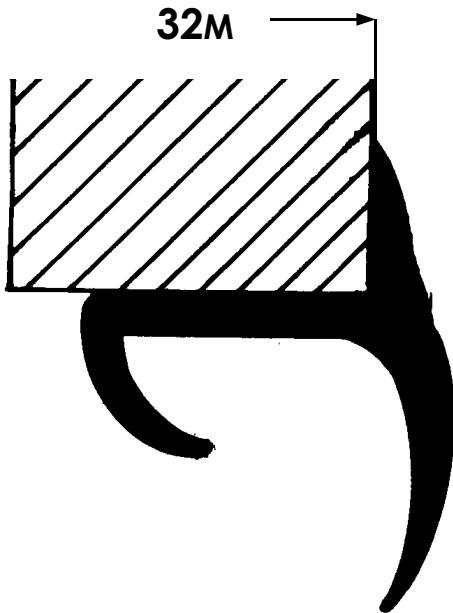
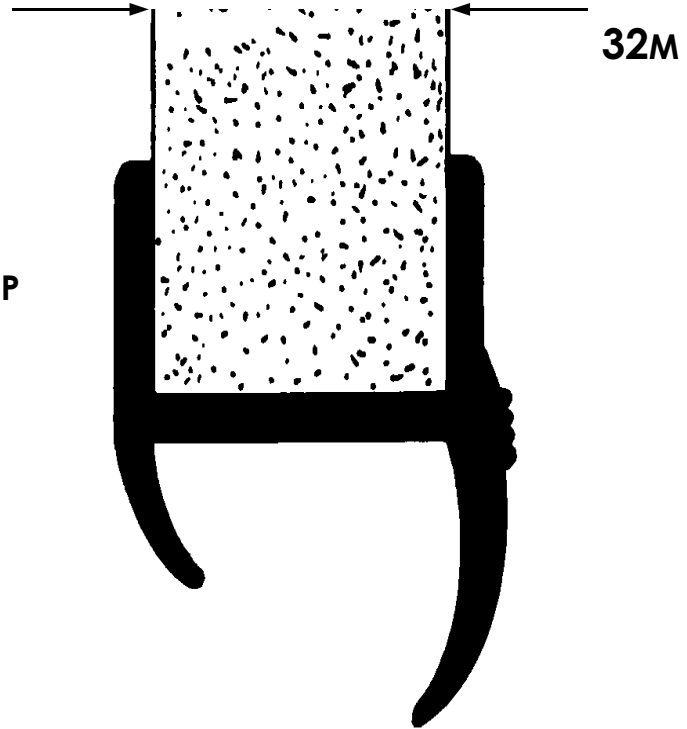

RES 32JL
LONG LIP

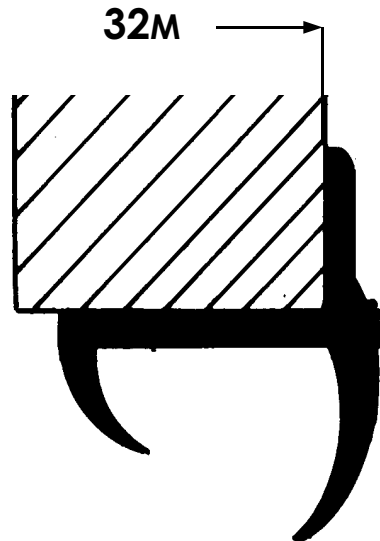

RES 32J
SINGLE LEG

ALL SUPPLIED IN 30 METRE COILS

PVC Extruded Industrial Door Seal

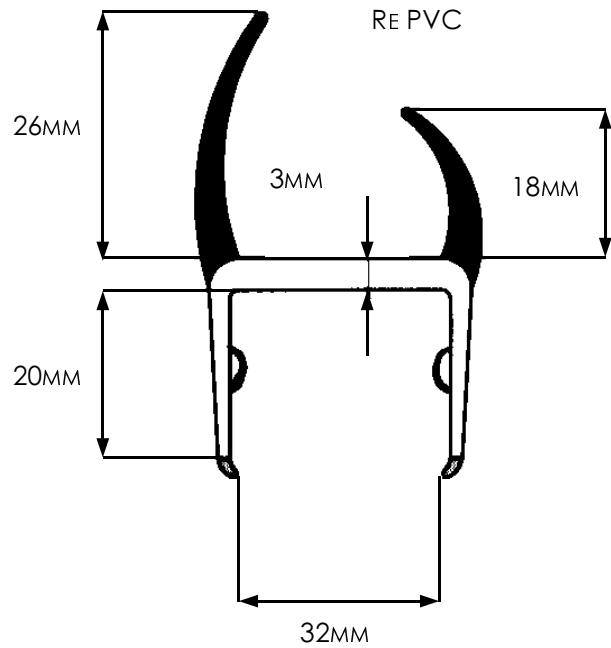
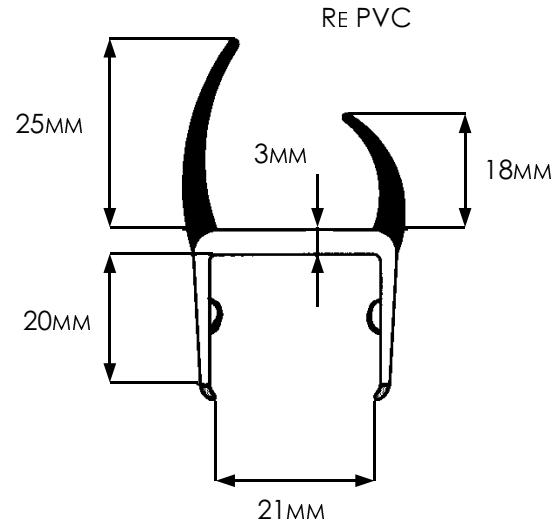
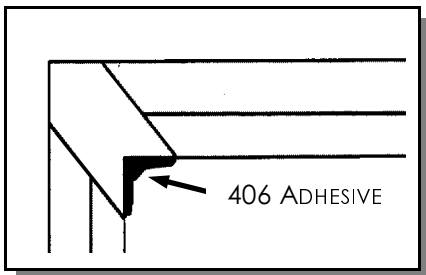
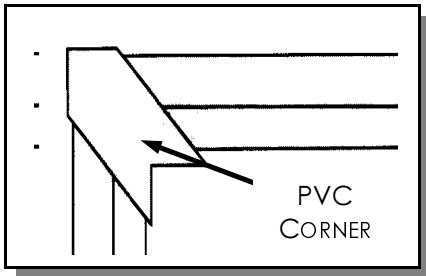
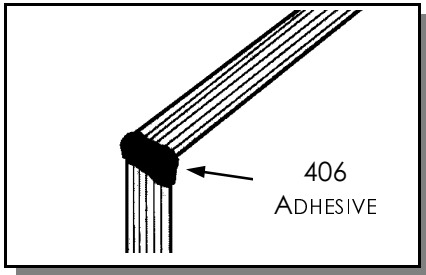
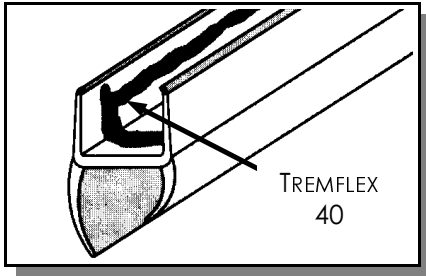
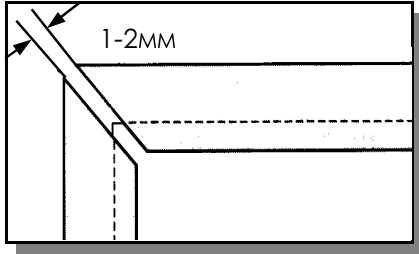

ALL SUPPLIED IN 4.5 METRE LENGTHS

Extruded Fender Rubber

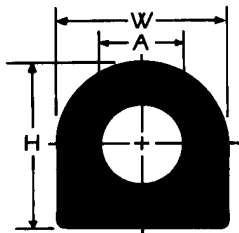

D - CIRCLE FENDER

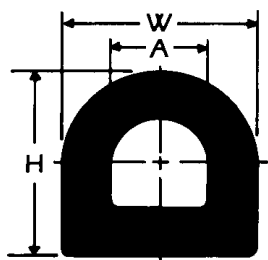
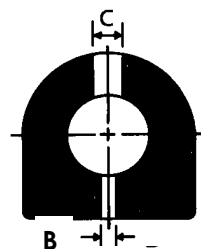
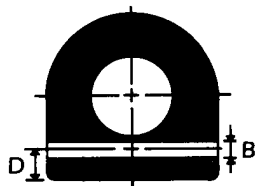

DD - FENDER

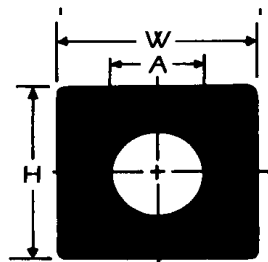
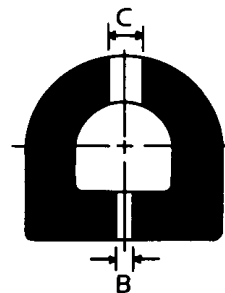
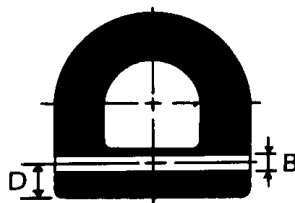

SQUARE CIRCLE FENDER

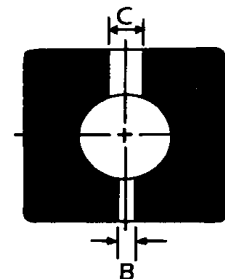
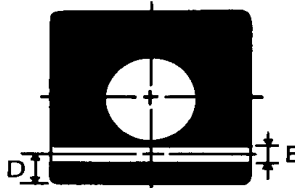

WING TYPE FENDER

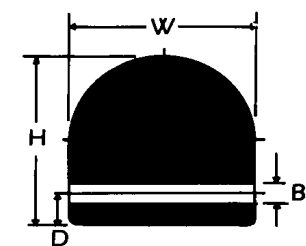
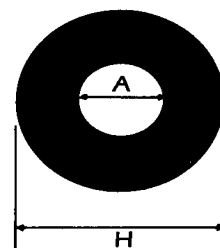
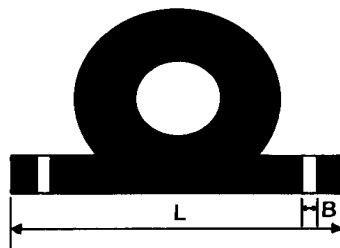
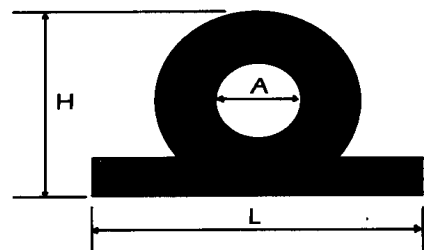

SOLID D FENDER

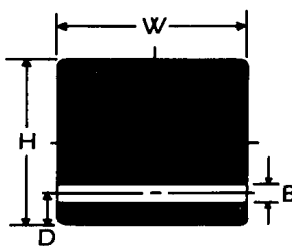
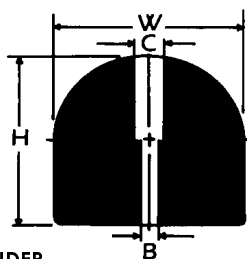

SOLID SQUARE FENDER

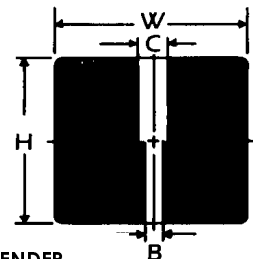

ITEM	150HW	200HW	250HW	300HW	350HW	400HW	500HW	600HW
H=W	150	200	250	300	350	400	500	600
A	75	100	125	150	175	200	250	300
B	20	24	28	32	36	40	44	48
C	50	55	65	70	75	80	90	100
D	22	30	40	50	60	70	90	110
L	230	305	400	460	-	-	-	-
BOLT SIZE	M16	M20	M24	M28	M32	M36	M40	M44

Extruded Fender Rubber

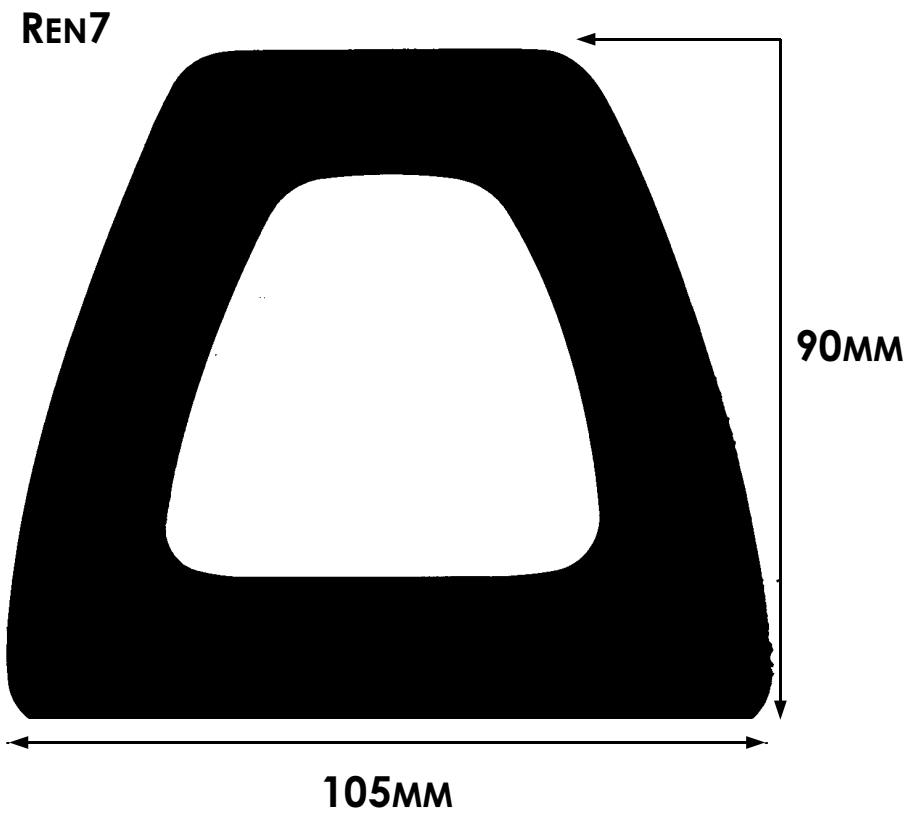
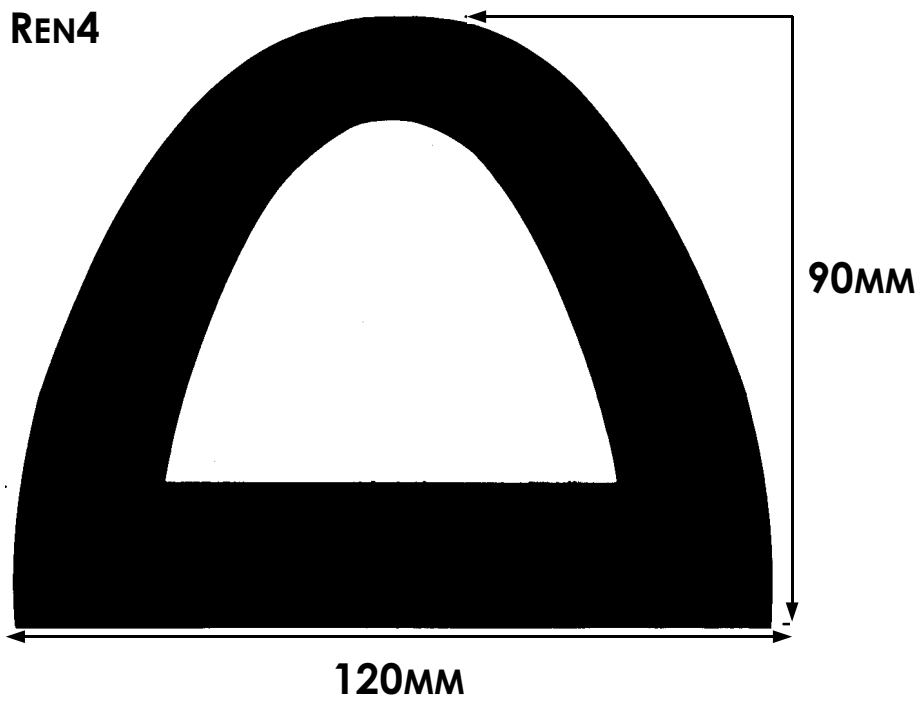

Extruded Rubber

Practical and inexpensive, Industrial Rubber extrusions are perfect for a huge variety of domestic and industrial uses. As you can see, we stock a large range of ready-made extrusions. But we also design and manufacture to suit your exact specifications. Which means that no matter what your requirements, Industrial Rubber can supply a rubber extrusion will fit the bill.



Re 503
Half round
strip 8mm x 4mm



Re 512
T. strip 25mm



Re 513
T. strip 19mm



Re 515
Scuttle rubber



Re 516
U. strip



Re 517
Quarter light strip



Re 518
T. strip 16mm



Re 520
T. strip 38mm



Re 522
T. strip 32mm



Re 523
Channel rubber



Re 525
Channel rubber



Re 526
Windscreen strip



Re 526/1
Windscreen strip



Re 529
Channel strip



Re 530
Scuttle rubber



Re 534
T. strip 13mm



Re 535
T. strip 45mm



Re 536
strip



Re 537
T. strip 16mm



Re 538
T. strip 38mm



Re 539
Windscreen casing



Re 540
Windscreen strip



Re 542
Windscreen strip



Re 543
Rubber strip

Extruded Fender Rubber

RE1830

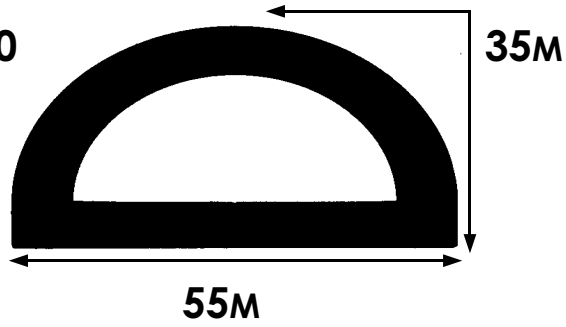

REN6

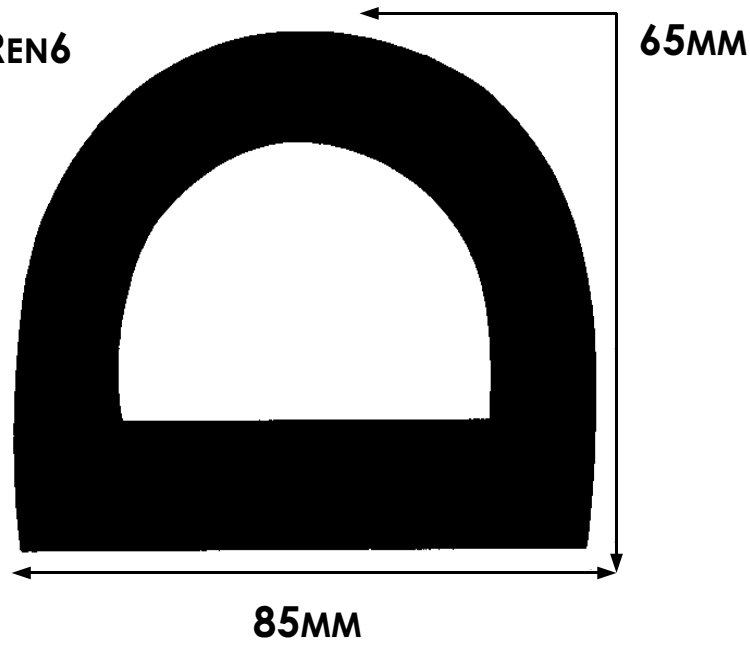

RE138

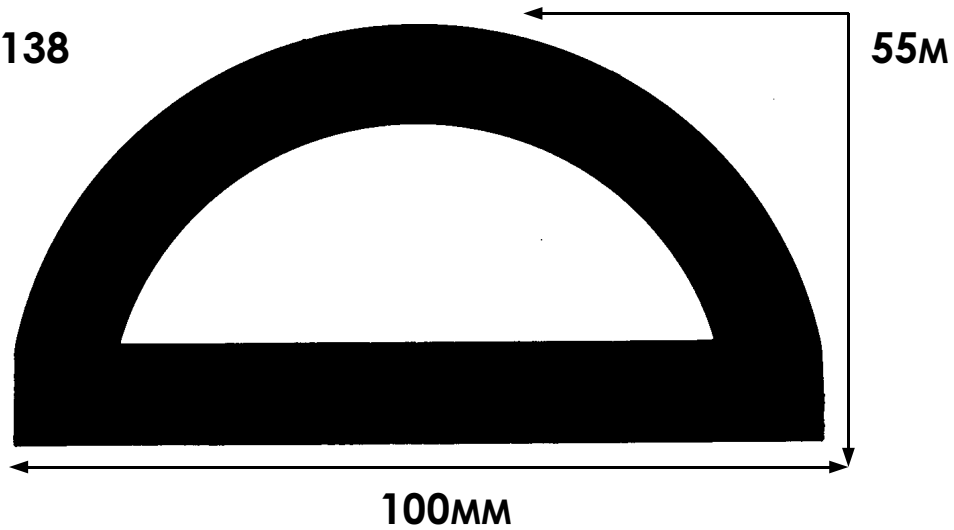

Extruded Fender Rubber

RE1440

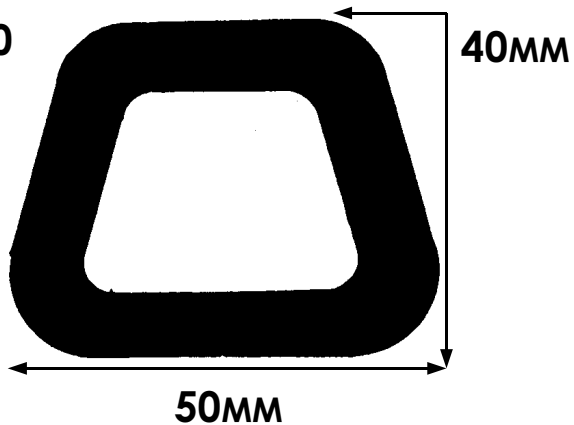

RE1441

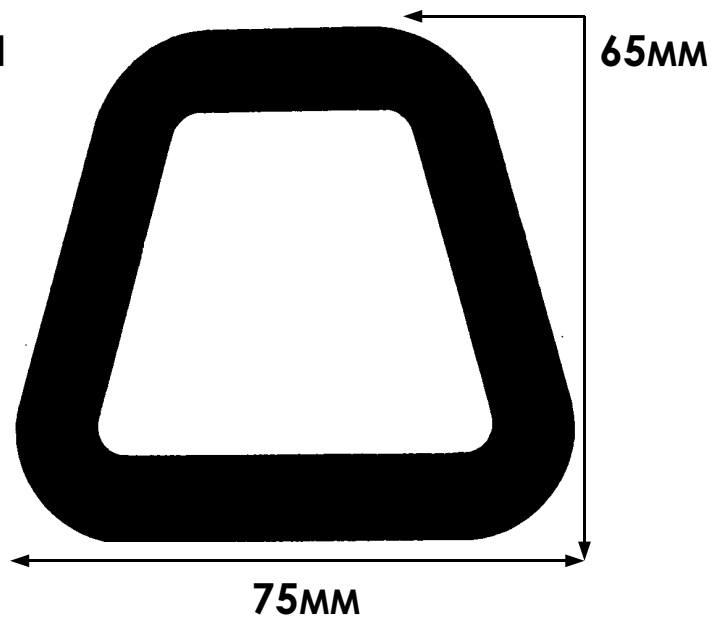

RE1442

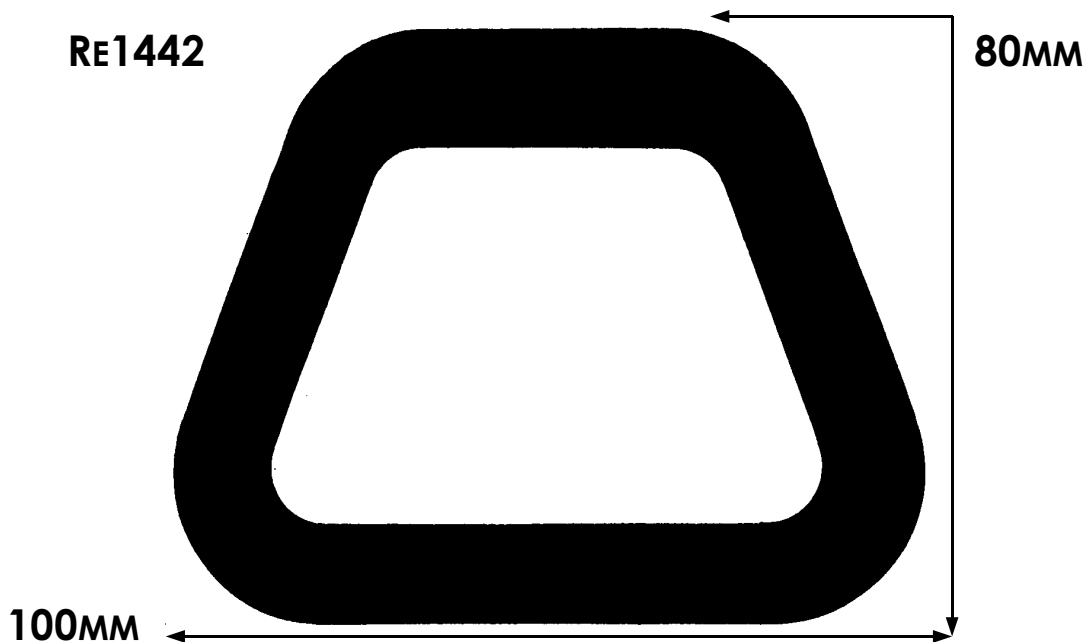

Extruded Fender Rubber

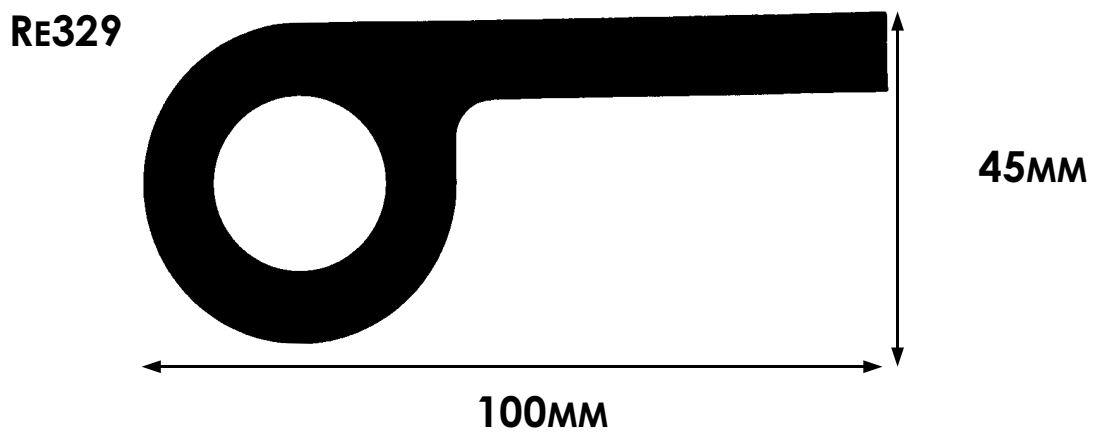
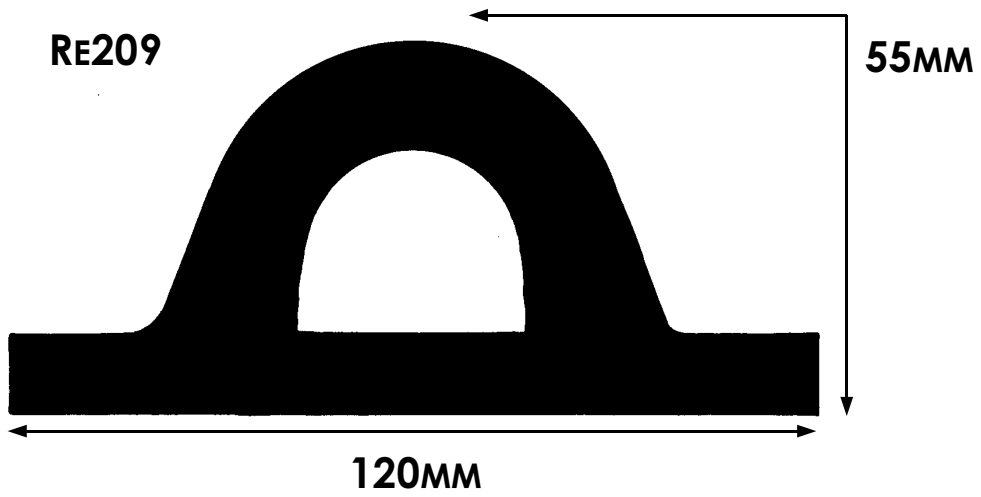
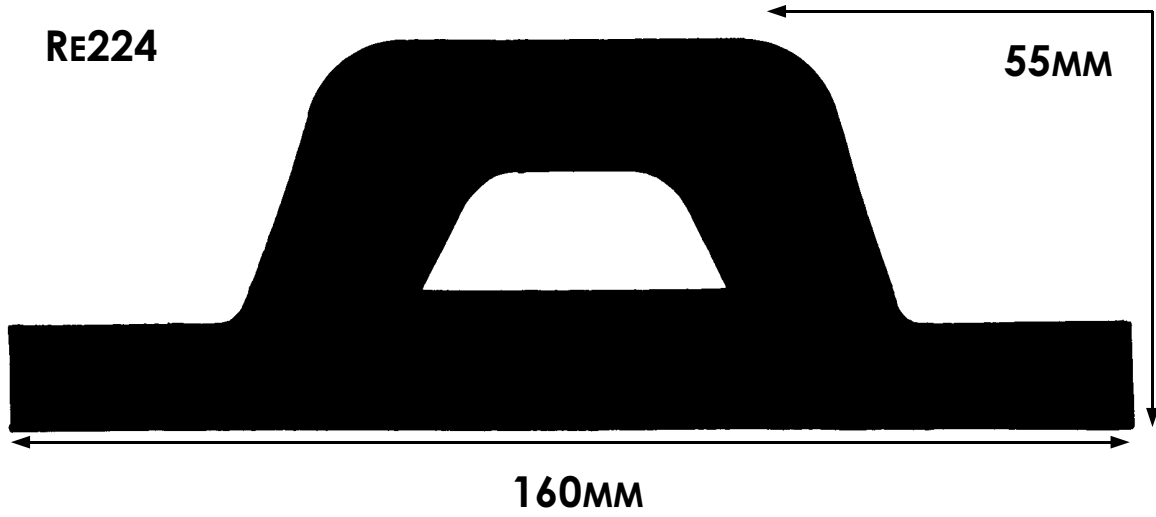

Extruded Rubber



Re 545
Windscreen strip



Re 546
Windscreen strip



Re 549
Channel rubber



Re 550
Windscreen strip



Re 551
Windscreen division/sec



Re 552
T. strip 10mm



Re 554
Cabinet beading



Re 556
U. strip 16mm



Re 557
U. strip 27mm



Re 558
Channel rubber



Re 559
Sealing strip



Re 560
U. strip



Re 562
Block strip



Re 563
Channel strip



Re 563/1
Channel strip



Re 564
U. strip soft



Re 566
Channel rubber



Re 567
Rubber strip



Re 568
Channel rubber



Re 569
U. rubber



Re 570
Channel rubber



Re 571
Windscreen strip



Re 575
Windscreen strip



Re 576
T. strip



Re 578
V. section strip

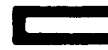

Re 582
Channel rubber



Re 583
Channel rubber



Re 584
Channel rubber



Re 588
Sealing strip



Re 589
Channel rubber

Extruded Rubber



Re 590
Channel rubber



Re 593
Channel rubber



Re 600
Channel rubber



Re 609
Channel rubber



Re 614
Channel rubber



Re 616
Beading strip



Re 620
Fluted strip



Re 621
Channel rubber



Re 625
Beading strip



Re 627
Channel rubber



Re 629
Channel rubber



Re 635
Sealing strip



Re 637
Channel strip



Re 638
Sealing strip



Re 640
Sealing strip



Re 624
Bezel strip

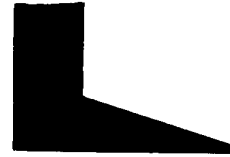

Re 643
Sealing strip



Re 646
Sealing strip



Re 647
Sealing strip



Re 648
Beading strip



Re 649
Weather strip



Re 650
Draught strip



Re 651
Channel rubber



Re 652
Channel rubber



Re 654
Block rubber



Re 659
Beading strip



Re 661
Channel rubber



Re 674
Rubber strip



Re 676
Channel rubber



Re 683
Sealing strip

Extruded Rubber

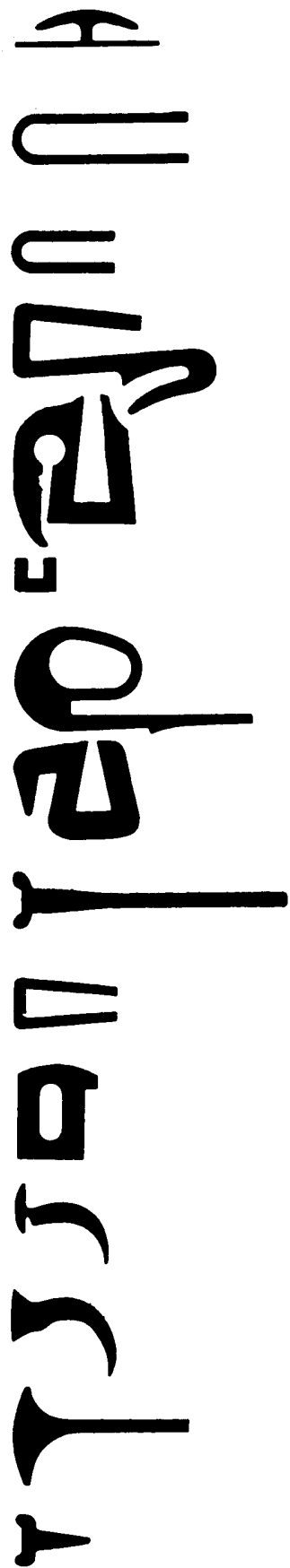

Re 684
Sealing strip

Re 688
U. strip

Re 689
U. strip

Re 694
Glazing strip

Re 695
Glazing strip

Re 697
Channel rubber

Re 701
Draught strip

Re 704
Windscreen strip

Re 705
T. strip

Re 708
Channel rubber

Re 716
Sealing strip

Re 717
Windscreen strip

Re 718
Windscreen strip

Re 721
T. strip

Re 722
T. strip

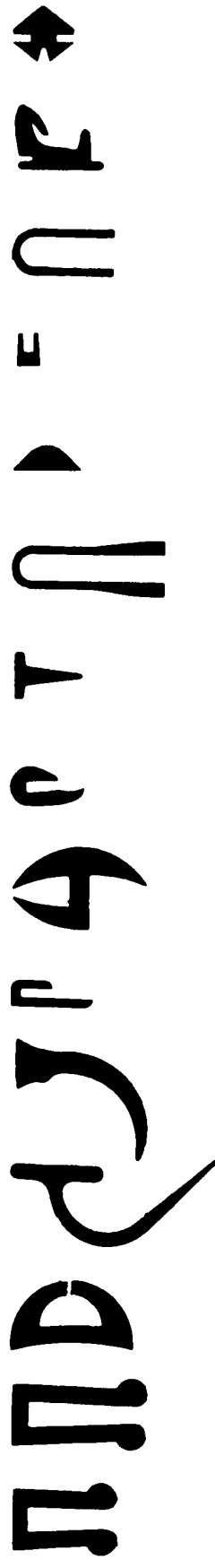

Re 723
Strip

Re 724
Strip

Re 726
U. strip

Re 729
Channel rubber

Re 733
Beading strip

Re 738
U. strip

Re 740
T. strip

Re 742
Sealing strip

Re 743
Sealing strip

Re 746
Sealing strip

Re 747
Windscreen strip

Re 748
Draught strip

Re 753
Sealing strip

Re 767
Channel rubber

Re 768
Channel rubber

Extruded Rubber



Re 776
U. strip



Re 777
Sealing rubber

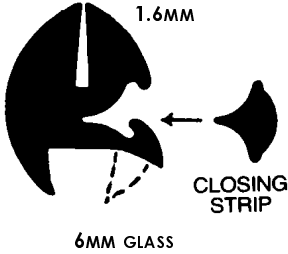

Re 778
Windscreen strip large

Re 779
Windscreen filler large

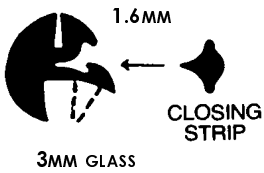

Re 780
Windscreen strip small

Re 781
Windscreen filler small



Re 782
Sealing rubber



Re 789
Beading strip



Re 791
Channel rubber



Re 796
Windscreen rubber



Re 799
Channel rubber



Re 838
Channel rubber



Re 855
Channel rubber



Re 866
Windscreen rubber



Re 885
Channel rubber



Re 904
H. strip (black)



Re 904/1
H. strip (white)



Re 915
Channel rubber



Re 920
Draught strip



Re 921
Channel rubber



Re 928
Windscreen strip medium



Re 929
Windscreen filler medium



Re 933
Channel rubber



Re 934
Channel rubber



Re 942
H. strip



Re 949
Channel rubber



Re 950
Sealing rubber



Re 977
Channel rubber



Re 978
Channel rubber



Re 998
Channel rubber

Extruded Rubber



Re 1007
Channel rubber

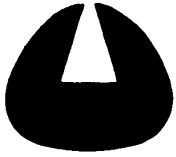

Re 1017
Channel rubber



Re 1019
Channel rubber



Re 1026
Channel rubber



Re 1032
Rubber strip



Re 1036
Channel rubber



Re 1044
Channel rubber



6MM
GLASS
TO
4.5 BODY

Re 1059 / 779
Windscreen strip large
use 779 filler strip



Re 1090
Windscreen strip



Re 1104
Channel rubber



Re 1130
H. strip



Re 1132
Channel rubber



Re 1201
White boat strip
(min order 150 mt lots)



6MM
GLASS
TO

Re 1204
Bus strip (use 929 filler)



Re 1244
H. section



Re 1303
Boat trailer strip



Re 528
Refrigerator strip



Re 681
Refrigerator strip



Re 532
Refrigerator strip



Re 715
Refrigerator strip

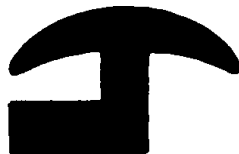

Re 553
Refrigerator strip



Re 719
Refrigerator strip



Re 597
Refrigerator strip



Re 734
Refrigerator strip



Re 617
Refrigerator strip



Re 736
Refrigerator strip

Extruded Rubber



Re 1216
Neoprene seal



Re 1219
Neoprene seal

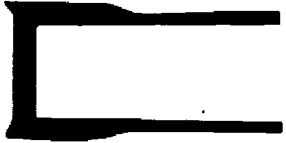

Re 1328
Cool room door gasket



Re 1329
Cool room door gasket



Re 1639
Neoprene



Re 1655
Switch board door seal



Re 1839
Neoprene



Re 1839s
Silicone



Re 1840
Neoprene



Re 1829
Rub rail white or black



Re 110
P section natural rubber
d/o available in sill cone



Re 107
P section natural rubber
d/o available in sill cone



Re 103
P section natural rubber
d/o available in sill cone



Re L 648
E.P.D.M.



Re Glazing wedge
E.P.D.M.

1.6MM GLASS

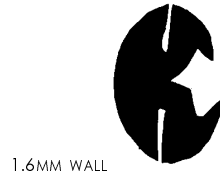

Re 1675
Windscreen strip

6MM GLASS



Re 1800/929
Windscreen rubber

10MM WALL

10MM GLASS



Re 1800/929-1
Windscreen rubber

6MM WALL



Re 47-004
Jag rubber
Made to order

Extruded Rubber

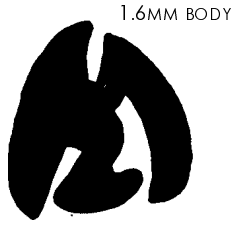

Re 1212
Self locking Windscreen

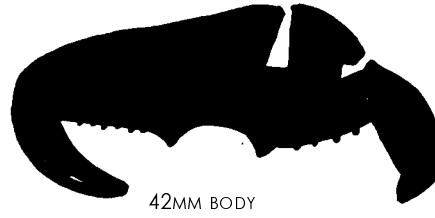

Re 1390
Bus rubber

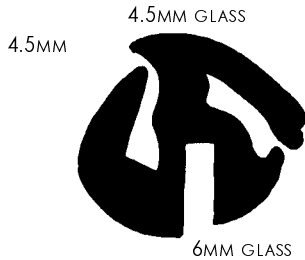

Re 1255
Self locking Windscreen

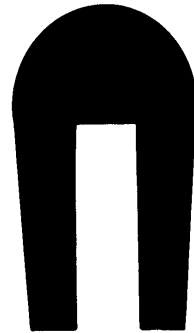

Re 264
Buffer strip



Re 1312
Self locking Windscreen

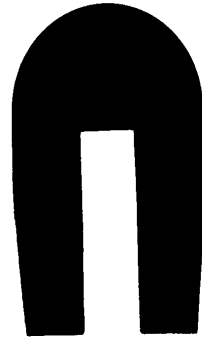

Re 279
Buffer strip

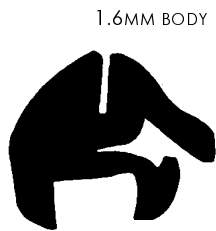

Re 1313
Self locking Windscreen

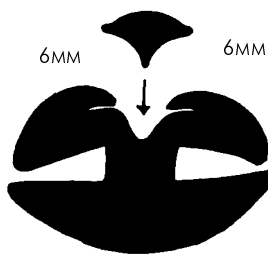

Re 1695/779
Windscreen rubber

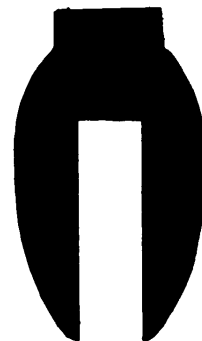

Re 528
Buffer strip

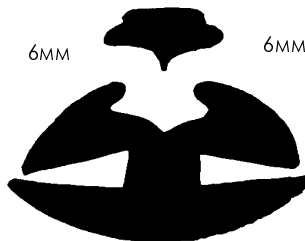

Re 51-004/992
Windscreen rubber



Re 87
Buffer strip

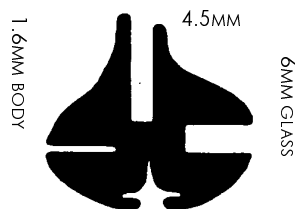

Re 7
3-way bus window

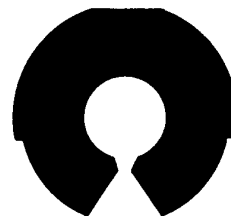

Re 1315
Buffer strip

GUNWALES ARE AVAILABLE IN WHITE BODY WITH BLACK CENTRE STRIP AND BLACK BODY WITH WHITE CENTRE STRIP

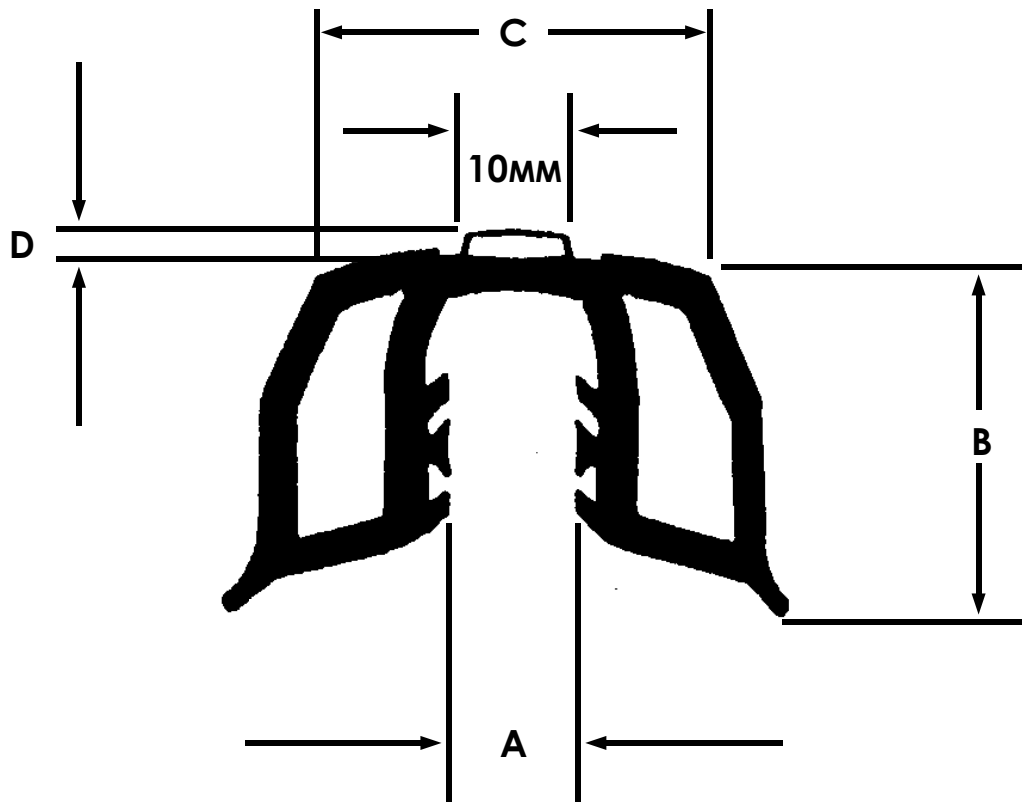

SECTION NUMBER	A	B	C	D
REPVC 451/502	7MM	30MM	30MM	5MM
REPVC 451/620	10MM	34MM	35MM	5-8MM
REPVC 451/800	11MM	37MM	38MM	6-5MM
REPVC 451/1000	12MM	40MM	44MM	7MM

Windscreen rubber insertion tool



365 0005
for insertion of filler sections
on tool 365 0001
tempered steel wire, shiny
Weight 1 g/pc
Sales Unit: 10 pc



365 0008
for insertion of filler sections
on tool 365 0001
tempered steel wire, shiny
Weight: 2 g/pc
Sales Unit: 10 pc



365 0006
for insertion of filler sections
on tool 365 0001
tempered steel wire, shiny
Weight 1 g/pc
Sales Unit: 10 pc



365 0009
for insertion of
trim filler sections
on tool 365 0001
tempered steel wire, shiny
Weight 3 g/pc
Sales Unit: 10pc



365 0007
for insertion of filler sections
on tool 365 0001
tempered steel wire, shiny
Weight 2 g/pc
Sales Unit: 10 pc



365 0010
for insertion of
trim filler sections
on tool 365 0001
tempered steel wire, shiny
Weight 4 g/pc
Sales Unit: 10 pc

